



ADG936/ADG936-R

FEATURES

- Wideband switch: -3 dB @ 4 GHz
- ADG936 absorptive dual SPDT
- ADG936-R reflective dual SPDT
- High off isolation (36 dB @ 1 GHz)
- Low insertion loss (0.9 dB dc to 1 GHz)
- Single 1.65 V to 2.75 V power supply
- CMOS/LVTTL control logic
- 20-lead TSSOP and 4 mm \times 4 mm LFCSP packages
- Low power consumption (1 μ A maximum)

APPLICATIONS

- Wireless communications
- General-purpose RF switching
- Dual-band applications
- High speed filter selection
- Digital transceiver front end switch
- IF switching
- Tuner modules
- Antenna diversity switching

GENERAL DESCRIPTION

The ADG936/ADG936-R are wideband analog switches that comprise two independently selectable SPDT switches using a CMOS process to provide high isolation and low insertion loss to 1 GHz. The ADG936 is an absorptive/matched dual SPDT with 50 Ω terminated shunt legs; the ADG936-R is a reflective dual SPDT. These devices are designed such that the isolation is high over the dc to 1 GHz frequency range. They have on-board CMOS control logic, eliminating the need for external controlling circuitry. The control inputs are both CMOS and LVTTL

FUNCTIONAL BLOCK DIAGRAMS

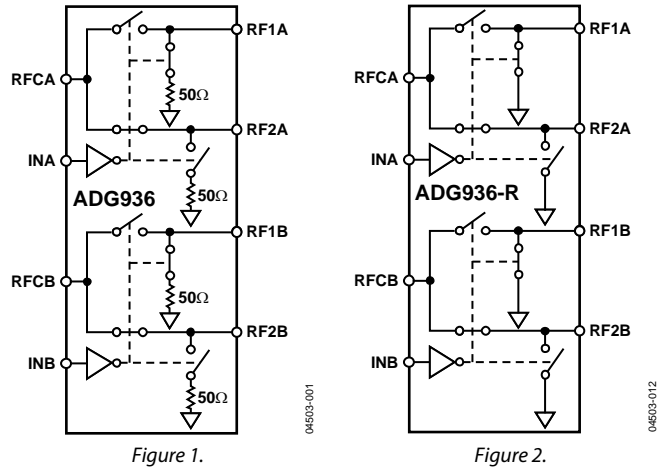

compatible. The low power consumption of these CMOS devices makes them ideally suited for wireless applications and general-purpose high frequency switching.

PRODUCT HIGHLIGHTS

- -36 dB off isolation @ 1 GHz.
- 0.9 dB insertion loss @ 1 GHz.
- 20-lead TSSOP and 4 mm \times 4 mm LFCSP packages.

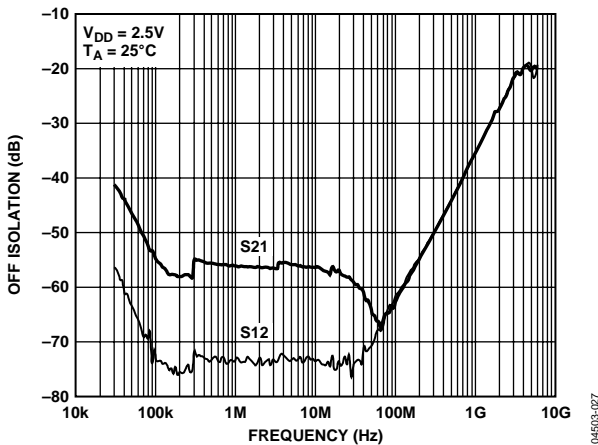

Figure 3. Off Isolation vs. Frequency

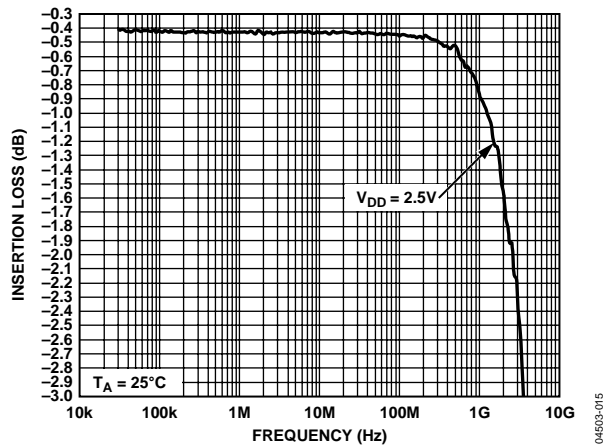

Figure 4. Insertion Loss vs. Frequency

Rev. A

Information furnished by Analog Devices is believed to be accurate and reliable. However, no responsibility is assumed by Analog Devices for its use, nor for any infringements of patents or other rights of third parties that may result from its use. Specifications subject to change without notice. No license is granted by implication or otherwise under any patent or patent rights of Analog Devices. Trademarks and registered trademarks are the property of their respective owners.

TABLE OF CONTENTS

Features	1	Typical Performance Characteristics	7
Applications.....	1	Test Circuits.....	9
Functional Block Diagrams.....	1	Applications.....	11
General Description	1	Absorptive vs. Reflective	11
Product Highlights	1	Filter Selection	11
Revision History	2	Tx/Rx Switching	11
Specifications.....	3	Antenna Diversity Switch.....	11
Absolute Maximum Ratings.....	4	Evaluation Board	12
ESD Caution.....	4	Outline Dimensions	13
Pin Configurations and Function Descriptions	5	Ordering Guide	14
Terminology	6		

REVISION HISTORY

8/05—Rev. 0 to Rev. A

Changes to Table 1.....	3
Changes to Figure 6.....	5
Changes to Ordering Guide	14

7/04—Revision 0: Initial Version

SPECIFICATIONS

$V_{DD} = 1.65\text{ V to }2.75\text{ V}$, $GND = 0\text{ V}$, input power = 0 dBm, all specifications T_{MIN} to T_{MAX} , unless otherwise noted.¹

Table 1.

Parameter	Symbol	Conditions	Min	B Version		Unit
				Typ ²	Max	
AC ELECTRICAL CHARACTERISTICS						
Operating Frequency ³			DC		2	GHz
3 dB Frequency ⁴					4	GHz
Input Power ⁴		0 V dc bias			7	dBm
		0.5 V dc bias			16	dBm
Insertion Loss	S_{21}, S_{12}	DC to 100 MHz; $V_{DD} = 2.5\text{ V} \pm 10\%$		0.4	0.5	dB
		500 MHz; $V_{DD} = 2.5\text{ V} \pm 10\%$		0.6	0.8	dB
		1000 MHz; $V_{DD} = 2.5\text{ V} \pm 10\%$		0.9	1.25	dB
Isolation—RFCx to RF1x/RF2x	S_{21}, S_{12}	100 MHz	52	60		dB
		500 MHz	40	47		dB
		1000 MHz	31	36		dB
Crosstalk—RF1x to RF2x	S_{21}, S_{12}	100 MHz	53	69		dB
		500 MHz	42	45		dB
		1000 MHz	34	37		dB
Return Loss (On Channel) ⁴	S_{11}, S_{22}	DC to 100 MHz	20	25		dB
		500 MHz	19	23		dB
		1000 MHz	16	24		dB
Return Loss (Off Channel) ⁴	S_{11}, S_{22}	DC to 100 MHz	18	24		dB
		500 MHz	17	23		dB
		1000 MHz	16	21		dB
On Switching Time ⁴	t_{ON}	50% CTRL to 90% RF		11	14	ns
Off Switching Time ⁴	t_{OFF}	50% CTRL to 10% RF		10	13	ns
Rise Time ⁴	t_{RISE}	10% to 90% RF		6.1	8	ns
Fall Time ⁴	t_{FALL}	90% to 10% RF		6	8	ns
1 dB Compression ⁴	$P_{-1\text{ dB}}$	1000 MHz		16		dBm
Third-Order Intermodulation Intercept	IP_3	900 MHz/901 MHz, 4 dBm	27.5	32		dBm
Video Feedthrough ⁵				3		mV p-p
DC ELECTRICAL CHARACTERISTICS						
Input High Voltage	V_{INH}	$V_{DD} = 2.25\text{ V to }2.75\text{ V}$	1.7			V
	V_{INH}	$V_{DD} = 1.65\text{ V to }1.95\text{ V}$	$0.65 V_{CC}$			V
Input Low Voltage	V_{INL}	$V_{DD} = 2.25\text{ V to }2.75\text{ V}$			0.7	V
	V_{INL}	$V_{DD} = 1.65\text{ V to }1.95\text{ V}$			$0.35 V_{CC}$	V
Input Leakage Current	I_I	$0 \leq V_{IN} \leq 2.75\text{ V}$		± 0.1	± 1	μA
CAPACITANCE⁴						
RF Port On Capacitance	$C_{RF\text{ ON}}$	$f = 1\text{ MHz}$		2.5		pF
Digital Input Capacitance	C_{DIG}	$f = 1\text{ MHz}$		2		pF
POWER REQUIREMENTS						
V_{DD}			1.65		2.75	V
Quiescent Power Supply Current	I_{DD}	Digital inputs = 0 V or V_{DD}		0.1	1	μA

¹ Temperature range of B Version: -40°C to $+85^\circ\text{C}$.

² Typical values are at $V_{DD} = 2.5\text{ V}$ and 25°C , unless otherwise noted.

³ Operating frequency is the point at which insertion loss degrades by 1 dB.

⁴ Guaranteed by design, not subject to production test.

⁵ Video feedthrough is the dc transience at the output of any port of the switch when the control voltage is switched from high to low or from low to high in a $50\ \Omega$ setup, measured with 1 ns rise time pulses and a 500 MHz bandwidth.

ADG936/ADG936-R

ABSOLUTE MAXIMUM RATINGS

T_A = 25°C, unless otherwise noted.

Table 2.

Parameter	Rating
V _{DD} to GND	-0.5 V to +4 V
Inputs to GND	-0.5 V to V _{DD} + 0.3 V ¹
Continuous Current	30 mA
Input Power	18 dBm
Operating Temperature Range	
Industrial (B Version)	-40°C to +85°C
Storage Temperature Range	-65°C to +150°C
Junction Temperature	150°C
TSSOP Package	
θ _{JA} Thermal Impedance	143°C/W
LFCSP Package	
θ _{JA} Thermal Impedance (4-Layer Board)	30.4°C/W
Lead Temperature, Soldering (10 sec)	300°C
IR Reflow, Peak Temperature (<20 sec)	235°C
ESD	1 kV

Stresses above those listed under Absolute Maximum Ratings may cause permanent damage to the device. This is a stress rating only; functional operation of the device at these or any other conditions above those indicated in the operational section of this specification is not implied. Exposure to absolute maximum rating conditions for extended periods may affect device reliability.

Only one absolute maximum rating may be applied at any one time.

Table 3. Truth Table

INx	RF1x	RF2x
0	Off	On
1	On	Off

¹ RF1x/RF2x off port inputs to ground = -0.5 V to V_{DD} - 0.5 V.

ESD CAUTION

ESD (electrostatic discharge) sensitive device. Electrostatic charges as high as 4000 V readily accumulate on the human body and test equipment and can discharge without detection. Although this product features proprietary ESD protection circuitry, permanent damage may occur on devices subjected to high energy electrostatic discharges. Therefore, proper ESD precautions are recommended to avoid performance degradation or loss of functionality.



PIN CONFIGURATIONS AND FUNCTION DESCRIPTIONS

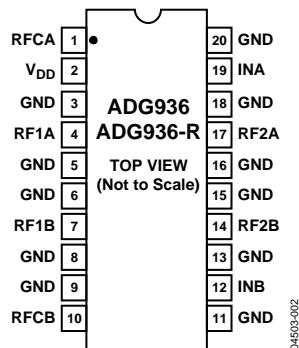
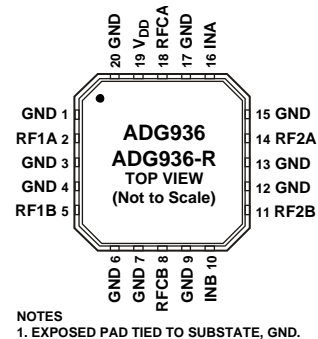

Figure 5. 20-Lead TSSOP (RU-20)



NOTES
1. EXPOSED PAD TIED TO SUBSTATE, GND.

Figure 6. 20-Lead 4 mm x 4 mm LFCSP (CP-20-1)

Table 4. Pin Function Descriptions

Pin No.		Mnemonic	Description
20-Lead TSSOP	20-Lead LFCSP		
1	18	RFCA	Common RF Port for Switch A.
2	19	V _{DD}	Power Supply Input. These parts can operate from 1.65 V to 2.75 V. V _{DD} should be decoupled to GND.
3, 5, 6, 8, 9, 11, 13, 15, 16, 18, 20	1, 3, 4, 6, 7, 9, 12, 13, 15, 17, 20	GND	Ground Reference Point for All Circuitry on the Part.
4	2	RF1A	RF1A Port.
7	5	RF1B	RF1B Port.
10	8	RFCB	Common RF Port for Switch B.
12	10	INB	Logic Control Input.
14	11	RF2B	RF2B Port.
17	14	RF2A	RF2A Port.
19	16	INA	Logic Control Input.

TERMINOLOGY

Table 5.

Parameter	Description
V _{DD}	Most Positive Power Supply Potential.
I _{DD}	Positive Supply Current.
GND	Ground (0 V) Reference.
IN _X	Logic Control Input.
V _{INL}	Maximum Input Voltage for Logic 0.
V _{INH}	Minimum Input Voltage for Logic 1.
I _{INL} (I _{INH})	Input Current of the Digital Input.
C _{IN}	Digital Input Capacitance.
t _{ON}	Delay Between Applying the Digital Control Input and the Output Switching On.
t _{OFF}	Delay Between Applying the Digital Control Input and the Output Switching Off.
t _{RISE}	Rise Time. Time for the RF signal to rise from 10% of the on level to 90% of the on level.
t _{FALL}	Fall Time. Time for the RF signal to fall from 90% of the on level to 10% of the on level.
Off Isolation	The Attenuation Between Input and Output Ports of the Switch When the Switch Control Voltage Is in the Off Condition.
Insertion Loss	The Attenuation Between Input and Output Ports of the Switch When the Switch Control Voltage Is in the On Condition.
Crosstalk	Measure of Unwanted Signal Coupled Through from One Channel to Another as a Result of Parasitic Capacitance.
P _{-1 dB}	1 dB Compression Point. The RF input power level at which the switch insertion loss increases by 1 dB over its low level value. P _{-1 dB} is a measure of how much power the on switch can handle before the insertion loss increases by 1 dB.
IP ₃	Third-Order Intermodulation Intercept. This is a measure of the power in false tones that occurs when closely spaced tones are passed through a switch, whereby the nonlinearity of the switch causes these false tones to be generated.
Return Loss	The Amount of Reflected Power Relative to the Incident Power at a Port. Large return loss indicates good matching. By measuring return loss, the voltage standing wave ratio (VSWR) can be calculated from conversion charts. VSWR indicates the degree of matching present at a switch RF port.
Video Feedthrough	Spurious Signals Present at the RF Ports of the Switch When the Control Voltage Is Switched from High to Low or from Low to High Without an RF Signal Present.

TYPICAL PERFORMANCE CHARACTERISTICS

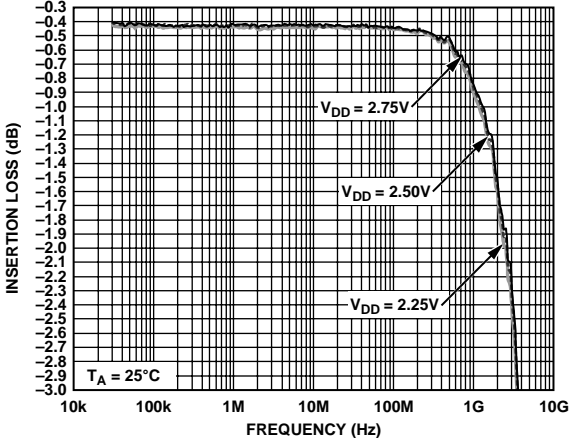

Figure 7. Insertion Loss vs. Frequency over Supplies (S12 and S21)

04503-015

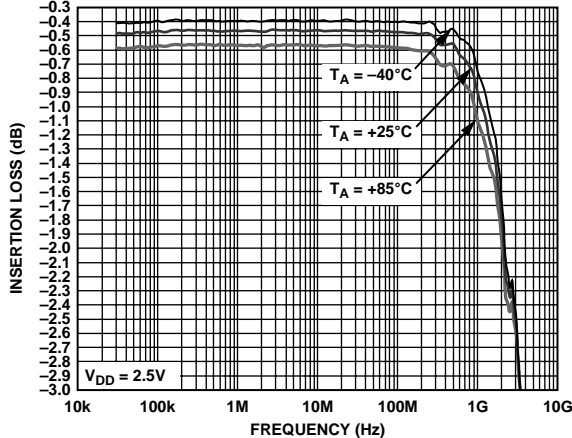

Figure 10. Insertion Loss vs. Frequency over Temperature (S12 and S21)

04503-018

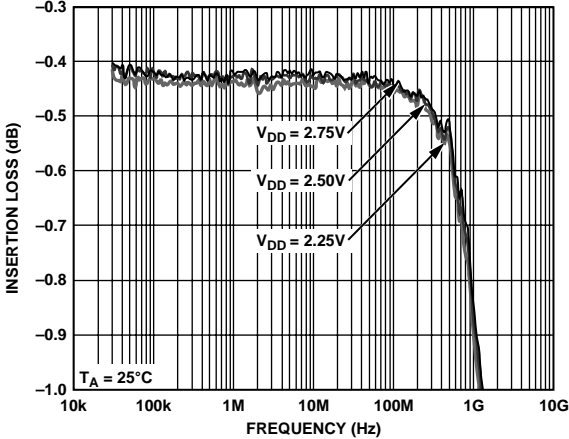

Figure 8. Insertion Loss vs. Frequency over Supplies (S12 and S21) (Zoomed Figure 7)

04503-016

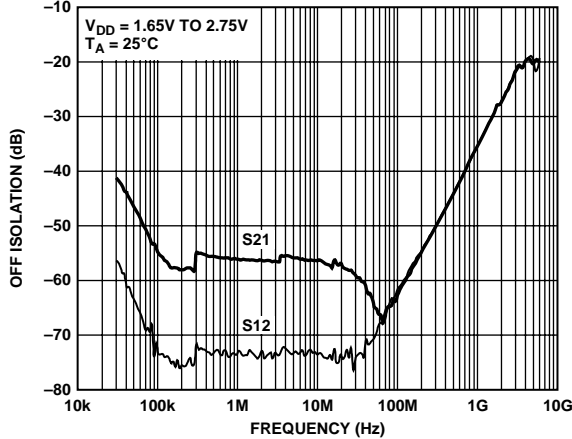

Figure 11. Isolation vs. Frequency over Supplies

04503-019

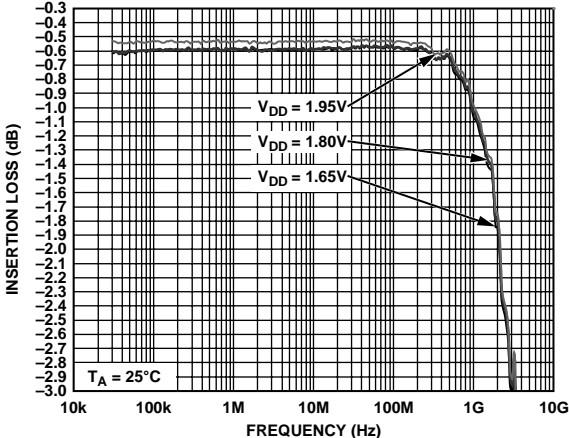

Figure 9. Insertion Loss vs. Frequency over Supplies (S12 and S21)

04503-017

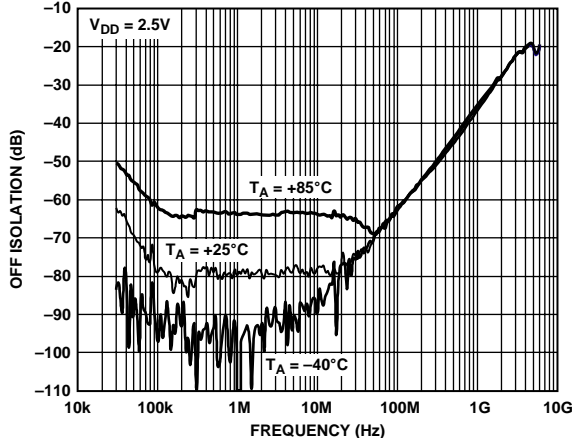

Figure 12. Isolation vs. Frequency over Temperature

04503-020

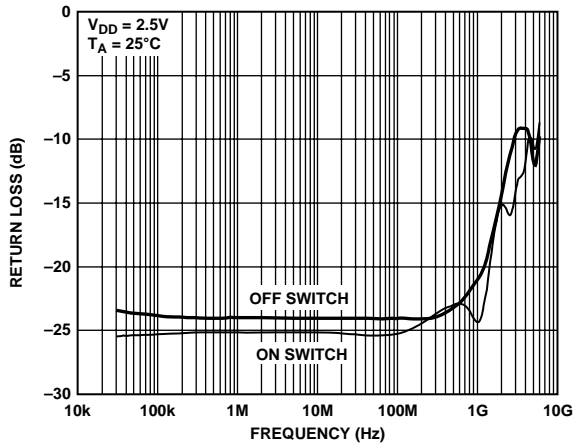

Figure 13. Return Loss vs. Frequency (S11)

04503-021

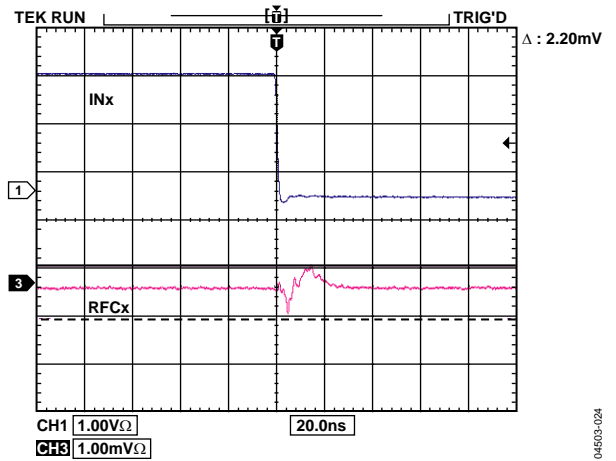

Figure 16. Video Feedthrough

04503-024

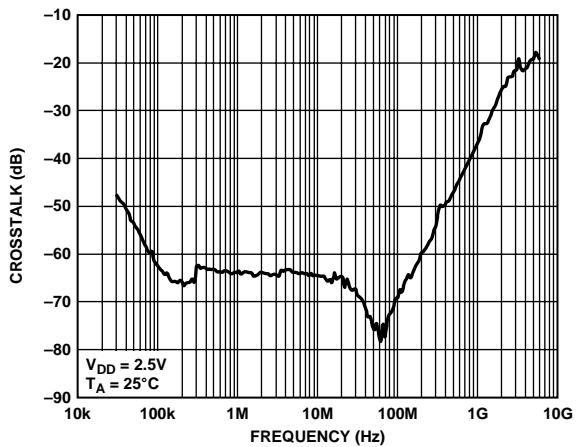

Figure 14. Crosstalk vs. Frequency (S12 and S21)

04503-022

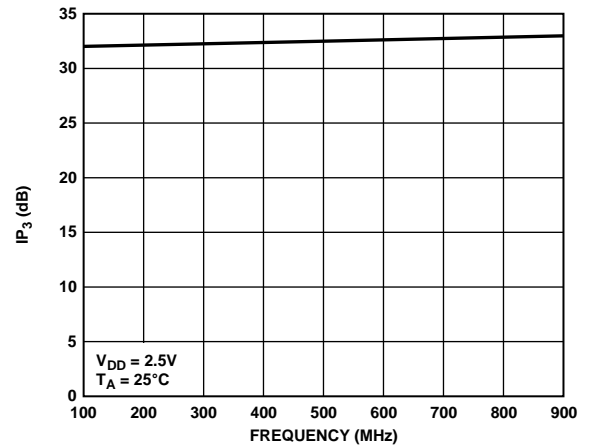

Figure 17. IP₃ vs. Frequency

04503-028

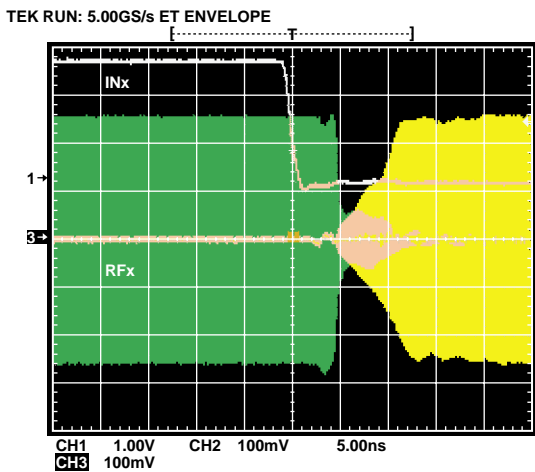

Figure 15. Switch Timing

04503-023

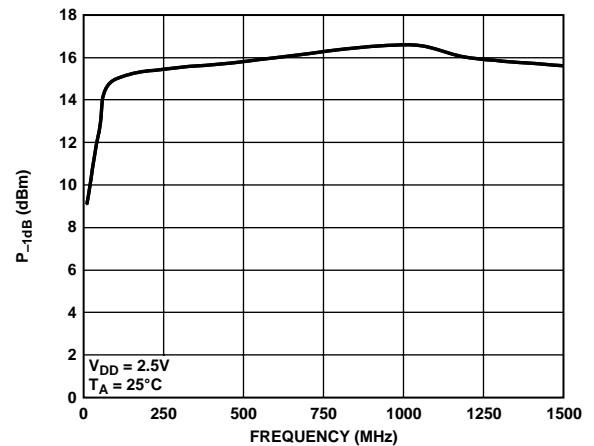

Figure 18. P_{-1dB} vs. Frequency

04503-025

TEST CIRCUITS

Similar setup for the ADG936. Additional pins omitted for clarity.

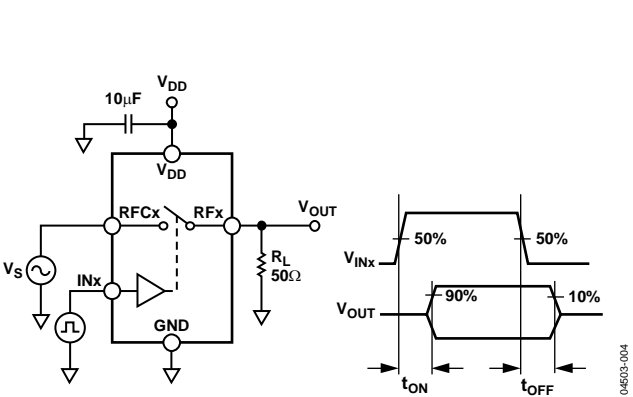

Figure 19. Switch Timing: t_{ON} , t_{OFF}

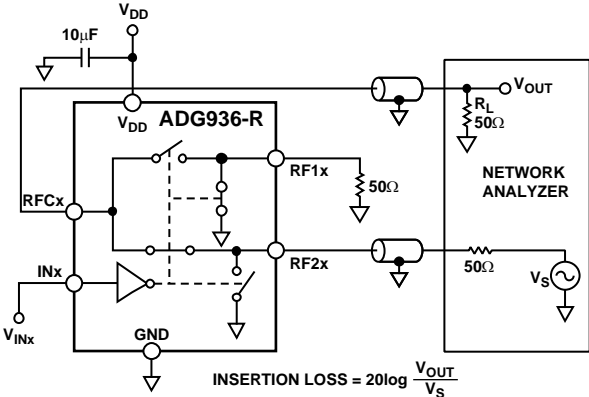

Figure 22. Insertion Loss

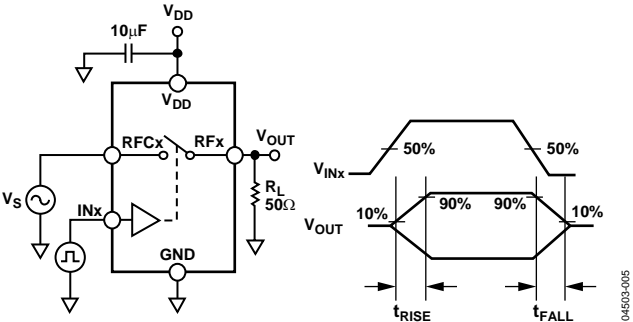

Figure 20. Switch Timing: t_{RISE} , t_{FALL}

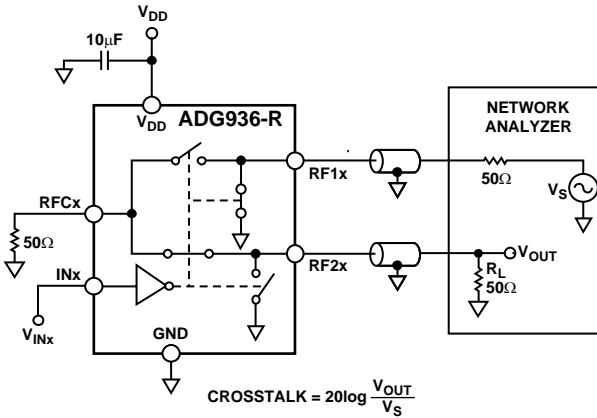

Figure 23. Crosstalk

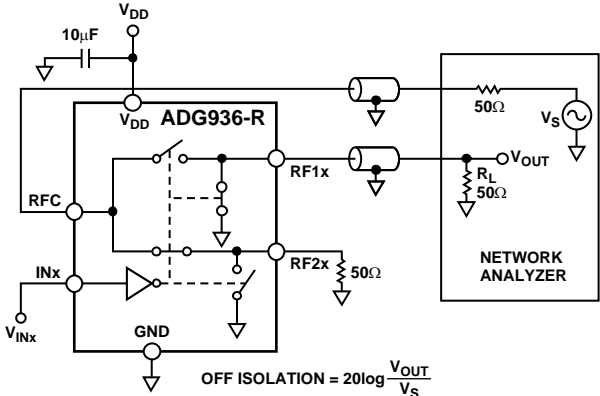

Figure 21. Off Isolation

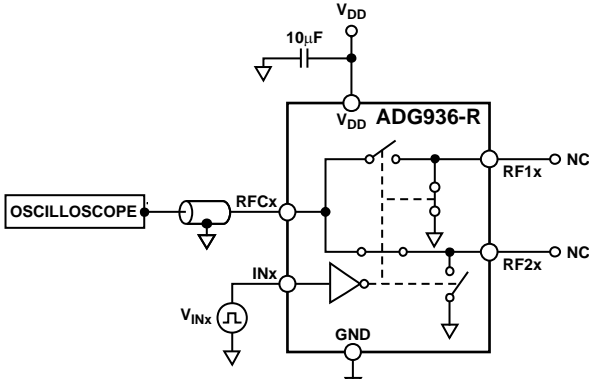

Figure 24. Video Feedthrough

ADG936/ADG936-R

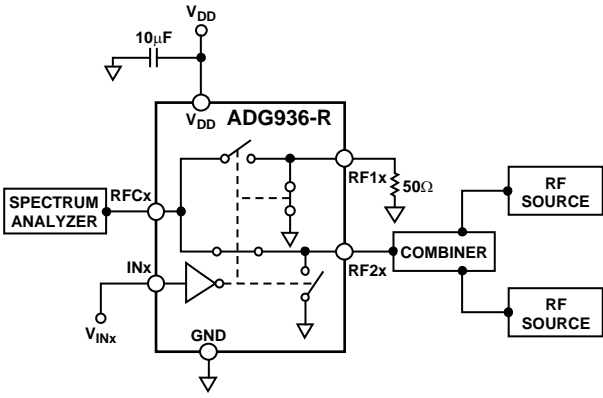

Figure 25. IP₃

04503-010

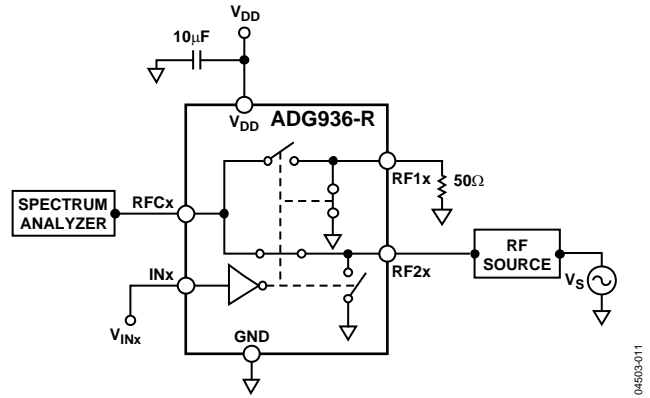

Figure 26. P_{-1dB}

04503-011

APPLICATIONS

The ADG936/ADG936-R are ideal solutions for low power, high frequency applications. The low insertion loss, high isolation between ports, low distortion, and low current consumption of these parts make them excellent solutions for many high frequency switching applications. They can be used in applications such as switchable filters, transmitters and receivers for radar systems, and communication systems from base stations to cell phones.

The ADG9xx family of wideband switches is designed to meet the demands of devices transmitting at ISM band frequencies to 1 GHz and higher. The low insertion loss, high isolation between ports, single pin control interface, no requirement for dc blocking capacitors, and TTL interface compatibility make them cost-effective and easy-to-integrate switching solutions for many high frequency switching and low power applications, because the parts can handle up to 16 dBm of power.

ABSORPTIVE VS. REFLECTIVE

The ADG936 is an absorptive (matched) switch with 50 Ω terminated shunt legs; the ADG936-R is a reflective switch with 0 Ω terminated shunts to ground. The ADG936 absorptive switch has a good VSWR on each port, regardless of the switch mode. An absorptive switch should be used when there is a need for a good VSWR that is looking into the port but not passing the through-signal to the common port. The ADG936 is, therefore, ideal for applications that require minimum reflections back to the RF source. It also ensures that the maximum power is transferred to the load.

The ADG936-R reflective switch is suitable for applications in which high off-port VSWR does not matter. The switch also has some other desired performance features. It can be used in many applications, including high speed filter selection. In most cases, an absorptive switch can be used instead of a reflective switch, but not vice versa.

FILTER SELECTION

The ADG936 and ADG936-R can be used to switch high frequency signals between different filters and to multiplex the signal to the output. These dual SPDT switches are also ideal for high speed signal routing and for switching high speed differential signals.

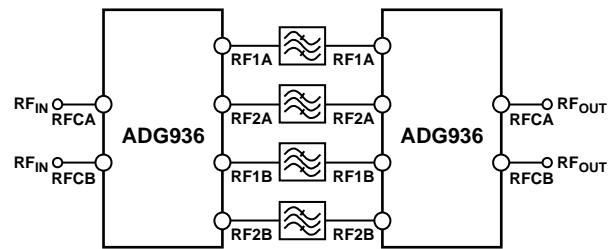

Figure 27. Filter Selection

04503-013

Tx/Rx SWITCHING

The low insertion loss and high isolation between ports ensure that the ADG936/ADG936-R are suitable transmit/receive switches for all ISM band and wireless LAN applications, providing the required isolation between the transmit and receive signals.

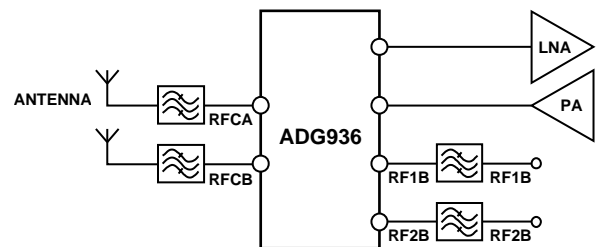

Figure 28. Tx/Rx Switching

04504-014

ANTENNA DIVERSITY SWITCH

The ADG936/ADG936-R are ideal for use as antenna diversity switches, switching in different antennas to the tuner. The low insertion loss, which ensures minimum signal loss and high isolation between channels, makes these dual SPDT switches suitable for switching applications in tuner modules and set-top boxes.

ADG936/ADG936-R

EVALUATION BOARD

The ADG936 and ADG936-R evaluation board allows designers to evaluate these high performance wideband switches with minimal effort.

To prove that these devices meet the user's requirements, only a power supply and a network analyzer, along with the evaluation board, are required. An application note available with the evaluation board gives complete information on operating the evaluation board.

The RFCA port is connected through a 50 Ω transmission line to SMA Connector J3. The RFCB port is connected through a 50 Ω transmission line to SMA Connector J4. RF1A, RF2A, RF1B, and RF2B are connected through 50 Ω transmission lines to SMA Connectors J5, J6, J7, and J8, respectively. A through transmission line connects J9 and J10; this transmission line is used to estimate the loss of the PCB over the environmental conditions being evaluated.

The board is constructed of a 4-layer FR4 material with a dielectric constant of 4.3 and an overall thickness of 0.062 in. Two ground layers with grounded planes provide ground for the RF transmission lines. The transmission lines were designed using a coplanar waveguide with a ground plane model using a trace width of 0.024 in, a clearance to ground plane of 0.008 in, a dielectric thickness of 0.02 in, and a metal thickness of 0.0021 in.

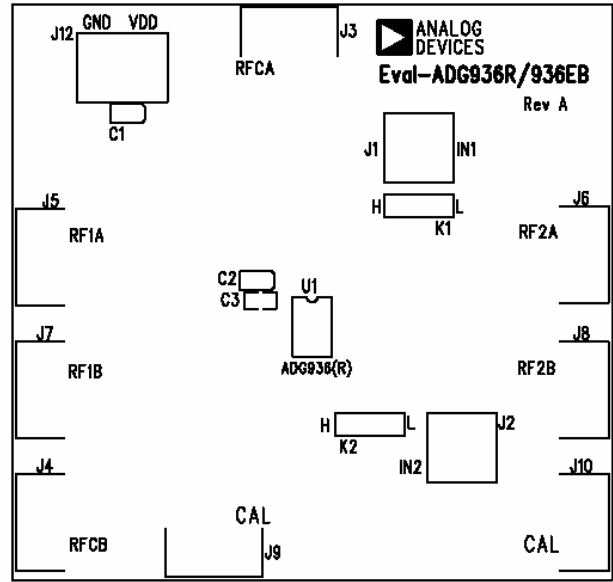

Eval-ADG936R/936EB Component Side View

Figure 29. ADG936 and ADG936-R Evaluation Board Top View

OUTLINE DIMENSIONS

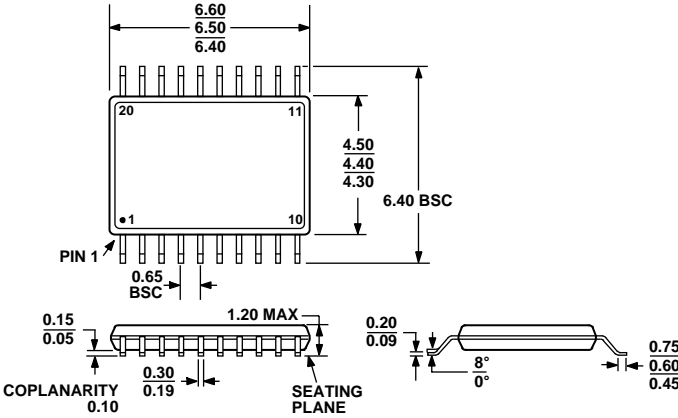

COMPLIANT TO JEDEC STANDARDS MO-153-AC
 Figure 30. 20-Lead Thin Shrink Small Outline Package [TSSOP]
 (RU-20)
 Dimensions shown in millimeters

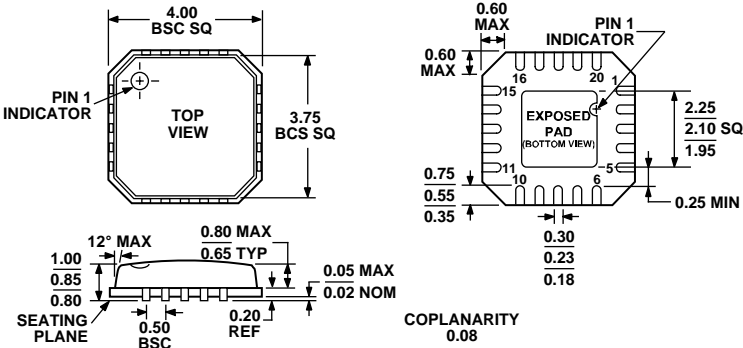

COMPLIANT TO JEDEC STANDARDS MO-220-VGGD-1
 Figure 31. 20-Lead Lead Frame Chip Scale Package [LFCSQ_VQ]
 4 mm × 4 mm Body, Very Thin Quad
 (CP-20-1)
 Dimensions shown in millimeters

ADG936/ADG936-R

ORDERING GUIDE

Model	Temperature Range	Package Description	Package Option
ADG936BRU	-40°C to +85°C	20-Lead Thin Shrink Small Outline Package (TSSOP)	RU-20
ADG936BRU-500RL7	-40°C to +85°C	20-Lead Thin Shrink Small Outline Package (TSSOP)	RU-20
ADG936BRU-REEL	-40°C to +85°C	20-Lead Thin Shrink Small Outline Package (TSSOP)	RU-20
ADG936BRU-REEL7	-40°C to +85°C	20-Lead Thin Shrink Small Outline Package (TSSOP)	RU-20
ADG936BRUZ ¹	-40°C to +85°C	20-Lead Thin Shrink Small Outline Package (TSSOP)	RU-20
ADG936BRUZ-REEL ¹	-40°C to +85°C	20-Lead Thin Shrink Small Outline Package (TSSOP)	RU-20
ADG936BRUZ-REEL7 ¹	-40°C to +85°C	20-Lead Thin Shrink Small Outline Package (TSSOP)	RU-20
ADG936BCP	-40°C to +85°C	20-Lead Lead Frame Chip Scale Package (LFCSP_VQ)	CP-20-1
ADG936BCP-500RL7	-40°C to +85°C	20-Lead Lead Frame Chip Scale Package (LFCSP_VQ)	CP-20-1
ADG936BCP-REEL	-40°C to +85°C	20-Lead Lead Frame Chip Scale Package (LFCSP_VQ)	CP-20-1
ADG936BCP-REEL7	-40°C to +85°C	20-Lead Lead Frame Chip Scale Package (LFCSP_VQ)	CP-20-1
ADG936BCPZ ¹	-40°C to +85°C	20-Lead Lead Frame Chip Scale Package (LFCSP_VQ)	CP-20-1
ADG936BCPZ-REEL ¹	-40°C to +85°C	20-Lead Lead Frame Chip Scale Package (LFCSP_VQ)	CP-20-1
ADG936BCPZ-REEL7 ¹	-40°C to +85°C	20-Lead Lead Frame Chip Scale Package (LFCSP_VQ)	CP-20-1
EVAL-ADG936EB		Evaluation Board	RU-20
ADG936BRU-R	-40°C to +85°C	20-Lead Thin Shrink Small Outline Package (TSSOP)	RU-20
ADG936BRU-R-500RL7	-40°C to +85°C	20-Lead Thin Shrink Small Outline Package (TSSOP)	RU-20
ADG936BRU-R-REEL	-40°C to +85°C	20-Lead Thin Shrink Small Outline Package (TSSOP)	RU-20
ADG936BRU-R-REEL7	-40°C to +85°C	20-Lead Thin Shrink Small Outline Package (TSSOP)	RU-20
ADG936BCP-R	-40°C to +85°C	20-Lead Lead Frame Chip Scale Package (LFCSP_VQ)	CP-20-1
ADG936BCP-R-500RL7	-40°C to +85°C	20-Lead Lead Frame Chip Scale Package (LFCSP_VQ)	CP-20-1
ADG936BCP-R-REEL	-40°C to +85°C	20-Lead Lead Frame Chip Scale Package (LFCSP_VQ)	CP-20-1
ADG936BCP-R-REEL7	-40°C to +85°C	20-Lead Lead Frame Chip Scale Package (LFCSP_VQ)	CP-20-1
EVAL-ADG936REB		Evaluation Board	RU-20

¹ Z = PB-free part.

NOTES

NOTES